



AR32J-2

ARTICULATING BOOM LIFT



- Machines feature a large platform, a dual capacity design, large chassis tilt angle, and better adaptability to various working conditions.
- Proportional control achieves excellent synchronization of composite actions and realizes precise micro-motion control for comfortable operations.
- Remote software upgrades, parameter adjustments, and remote online diagnosis through telematics.
- Equipped with the intelligent self-diagnosis function, which facilitates convenient fault detection when the equipment arrives at or departs from the site.

The 2 Series

ARTICULATION BOOM LIFT

SPECIFICATIONS

MODELS	AR32J-2 (AR105J-2)	
Measurements	Metric	Imperial
Work Height Max.	34.2m	112'2"
Platform Height Max.	32.2m	105'8"
Horizontal Outreach	20.43m	67'
Up and Over Height	14.46m	47'5"
Platform Length	2.44m	8'
Platform Width	0.9m	2'11"
A Stowed Length	12.7m	41'8"
Length-Transport (jib tucked)	12.7m	41'8"
B Overall Width (axles retracted)	2.37m	7.78'
C Overall Width (axles extended)	3.97m	13.02'
D Stowed Height	2.81m	9'3"
Height-Transport	2.81m	9'3"
E Wheelbase	4.15m	13'7"
F Ground Clearance	0.31m	1'

PRODUCTIVITY		
Max. Platform Occupants	2(unrestricted)/3(restricted)	
Platform Capacity (unrestricted/restricted)	260/350kg	573/772 lbs
Turntable Rotation	360°	
Drive Speed-Stowed	5km/h	3.1mph
Drive Speed-Raised	0.6km/h	0.4mph
Gradeability	45%	
Max. Wind Speed	12.5m/s	28mph
Turning Radius-Inside (axles retracted)	6.6m	21'8"
Turning Radius-Outside (axles retracted)	9m	29'6"
Turning Radius-Inside (axles extended)	2.6m	8'6"
Turning Radius-Outside (axles extended)	6.2m	20'4"
Max. Working Slope	5°/5°	
Tires Type	Foam-filled	
Tires Models	385/45-28	

POWER		
Power Source	Kubota 54.6kW/73.2hp	
Fuel Tank Capacity	100L	26.4gal

HYDRAULIC SYSTEM		
Hydraulic Oil Volume	200L	52.8gal

WEIGHT		
Machine Weight	18,900kg	41,667 lbs

STANDARD FEATURES
Auto-leveling platform
Hydraulic rotating platform 180°
Full proportional joystick control
Descent alarm
Flashing beacons
Horn/Hour meter
Over-tilt protection system
Emergency stop button
Intelligent self-diagnosis function
Cylinder bellows
OTA remote upgrade
Dustproof components
Over-head anti-collision protection
Platform tool box

OPTIONAL
AC power to platform
Platform work light
Half-height mesh platform
Platform auxiliary guardrail
Platform pipe rack

MACHINE SIZE / WORKING RANGE

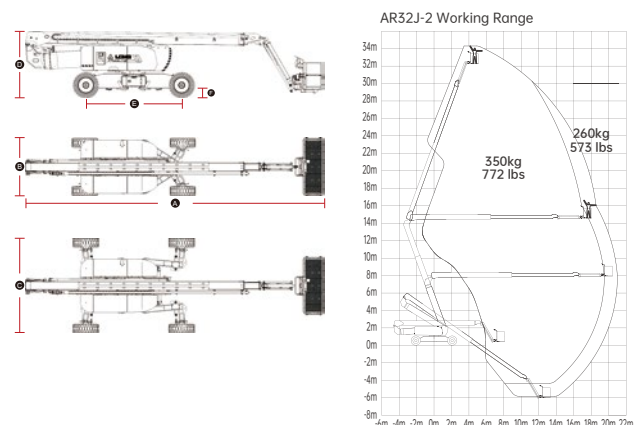

Please contact LGMG or a local dealer for more details.

LGMG reserves the right to change technical data without prior notice. All photos and pictures in this brochure are for promotional purposes only.